

Product lineup



Product image



TD96(G-L)

Features

- Outer mounting diameter of $\varnothing 25$ mm
- One direction rotary damper
- The mounting flange corresponds to the bottom face

Product name	Torque [mN·m] (lb·in)	Damping direction	Cap color
TD96R1-500	50.0 ± 10 (0.44 ± 0.09)	CW	Dark gray
TD96R1-1000	100.0 ± 20 (0.89 ± 0.18)		
TD96R1-1500	150.0 ± 30 (1.33 ± 0.27)		

Product name	Torque [mN·m] (lb·in)	Damping direction	Cap color
TD96L1-500	50.0 ± 10 (0.44 ± 0.09)	CCW	Gray
TD96L1-1000	100.0 ± 20 (0.89 ± 0.18)		
TD96L1-1500	150.0 ± 30 (1.33 ± 0.27)		

The torque of all rotary dampers is measured at a rotational speed of 20 min⁻¹.

The products without gear have "(G-L)" at the end of the product name.

Bidirectional TD96 rotary dampers are not available.

Product specifications

Durability

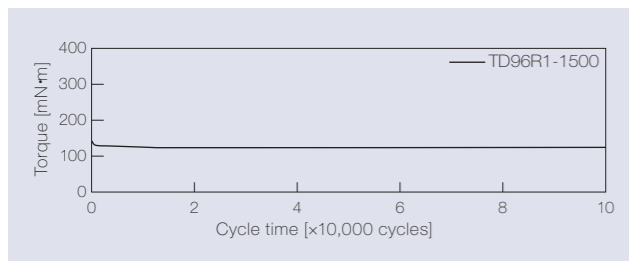

Measurement of torque at a rotation speed of 20 min⁻¹

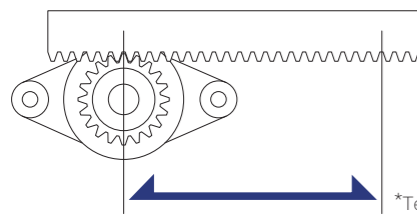

*Test conducting image

Test method	Rack-and-pinion
Travel speed	20 mm / sec
Pinion rotation speed	30 min ⁻¹
Damper rotation frequency	One rotation in the CW and CCW directions, respectively
Durability	100,000 cycles

Temperature characteristics

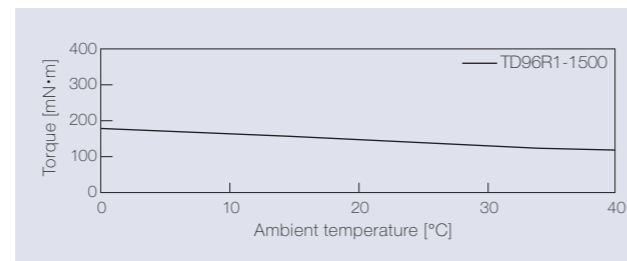

The torque achieved during rotation at 20 min⁻¹ in the designated ambient temperature is shown.

Speed characteristics

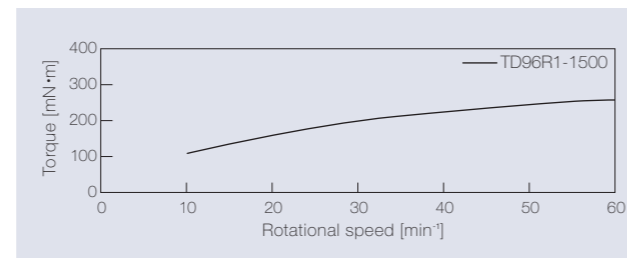

Product information

TD96 [mm]

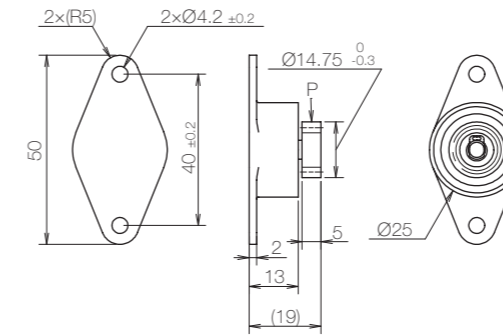

TD96(G-L) [mm]

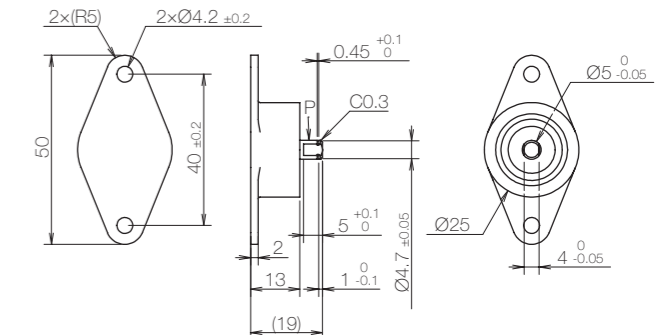

* General tolerance: ±0.3

Gear specifications

Type	Standard spur gear
Tooth profile	Involute and full depth tooth
Module	1
Pressure angle	20°
Number of teeth	12
P.C.D[mm]	Ø 12
Addendum modification	+0.375
Base tangent length / Number	4.85 / 2

- Product weight: Approx. 13 g (With gear)
- Allowable radial load (P): 13.4 N

Main materials

Housing	Plastic (PC)
Cap	Plastic (PC)
Gear	Plastic (POM)
Shaft	Stainless steel (SUS)

Dimensions related to mounting

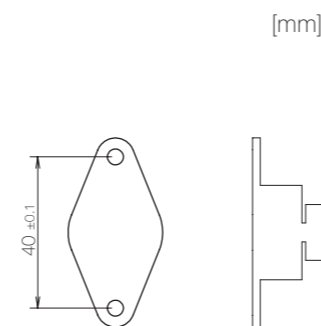

Damping directions

Damping direction of the shaft

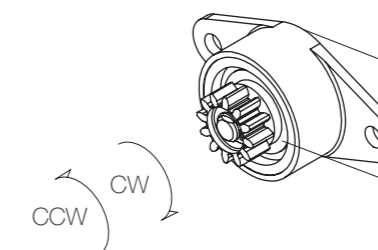

Damping direction	Printed mark
CW	R
CCW	L

Damping direction	Cap color
CW	Dark gray
CCW	Gray